

Aerodynamically optimised
splitter frame



Tested to VDI 6022

Attenuators

MK



Splitter with high insertion loss and broadband attenuation even in the low frequency range

Sound attenuator splitters with resonating panels, ready to be used in ventilation and air conditioning systems

- Attenuation effect due to absorption and resonance
- Energy efficient due to aerodynamically formed frame (bullnose radius 0.8")
- Acoustic data measured to EN ISO 7235
- Sound absorbing material is biosoluble and hence hygienically safe
- Sound absorbing material faced with glass fibre fabric as a protection against erosion due to airflow velocities up to 3937 fpm
- The sound absorbing material is non-combustible, to EN 13501, fire rating class A1
- For use in areas with potentially explosive atmospheres (according to EC Directive 2014/34/EU (ATEX)), zones 1, 2, and zones 21 and 22 (outside) according to EC Directive 1999/92/EC
- Operating temperature up to 212 °F, with expanded metal (variant L) up to 572 °F for a limited period of time

Optional equipment and accessories

- Expanded metal as an additional mechanical protection for the sound absorbing material
- Stainless steel variant A2 (1.4301), with optional perforated metal facing as an additional protection for the sound absorbing material
- Other stainless steel and aluminium variants as well as PUR coating are upon request
- Fitting accessories to join subdivided attenuator splitters

General information	2	Dimensions	9
Function	3	Weights	9
Technical data	5	Installation details	12
Quick sizing	5	Accessories – variant ACC	15
Specification text	7	Nomenclature	16
Order code	8		

General information

Application

- Sound attenuator splitters with resonating panels are used for the reduction of fan and air-regenerated noise in ventilation and air conditioning systems
- Attenuation effect due to absorption and resonance
- Broadband attenuation even in the low frequency range of critical fan noise
- Hygiene tested and compliant with VDI 6022
- For use in areas with potentially explosive atmospheres (EC Directive 2014/34/EU (ATEX)), zones 1, 2, 21 and 22 (outside) according to Directive 1999/92/EC

Special features

Resonating panels ensure increased insertion loss in the frequency range of critical fan noise

- Energy savings due to aerodynamically formed splitter frame
 - Up to 30 % lower differential pressure
- Hygiene tested and compliant with VDI 6022
- Multi-section construction available for large dimensions

Nominal sizes

- H: 6" – 98"
- L: 20", 30", 39", 49", 59", 69", 79", 89", 98"
- Intermediate sizes of H and L are possible: 6" – 98" in increments of 0.04"
- Undivided construction: H + L 24" min., 157" max., 220 lbs max.
 - Size limit for H or L: If one dimension is greater than 59", the other one must not exceed 59"
- Height and length subdivided in case of deviation, or a dimension 98" – 197"
 - Height subdivided from H ≥ 98", otherwise length subdivided

Variants

- MK4: splitter thickness 4"
- MK8: splitter thickness 8"
- MK9: splitter thickness 9"

Construction

Half of the splitter is covered by a resonating panel

- F: Glass fibre fabric
- L: glass fibre fabric faced with expanded metal as an additional mechanical protection for the sound absorbing material

Materials and surfaces

- No entry: Galvanised steel 1.0917
- A2: Stainless steel 1.4301
 - Construction L: Glass fibre fabric with perforated metal facing as an additional mechanical protection for the sound absorbing material
- P1: Powder-coated RAL 7001, silver grey

Parts and characteristics

- Aerodynamically profiled frame
 - Reduced weight and increased rigidity due to special profile
 - Helps to optimise the airflow, hence reducing the air-regenerated noise
 - Reduces the pressure loss
 - Covers the edges of the sound absorbing material
- Absorption material and resonating panels fitted to reduce air-regenerated noise by absorption and resonance

Accessories

- U-sheets/clamp sheets to join subdivided attenuator splitters (included with subdivided splitter constructions)

Construction features

- Aerodynamically formed splitter frame (bullnose radius 0.8") that helps to reduce turbulence on both the upstream and downstream sides; frame with grooves for increased rigidity
- Frame edges with bullnose to protect the infill
- Operating temperature up to 212 °F; variant L up to 572 °F for 8h max.

Materials and surfaces

- Splitter frames, centre mullion and resonating panels made of galvanised sheet steel 1.0917 or stainless steel 1.4301
- Expanded metal facing made of galvanised steel 1.0917
- Perforated metal facing made of stainless steel 1.4301
- Absorption material is mineral wool
 - To EN 13501, fire rating Class A1, non-combustible
 - RAL quality mark RAL-GZ 388
 - Biosoluble and hence non-hazardous to health according to the German TRGS 905 (Technical Rules for Hazardous Substances) and EU Directive 97/69/EC
 - Faced with glass fibre fabric as a protection against erosion from airflow velocities of up to 3937 fpm
 - Inert to fungal and bacterial growth according to EN 846

Standards and guidelines

- Insertion loss and sound power level of air-regenerated noise tested to ISO 7235
- Meets the hygiene requirements of VDI 6022, VDI 3803 Part 1 and DIN 1946 Part 4
- EC Directive 2014/34/EC (ATEX): Equipment and protective systems intended for use in areas with potentially explosive atmospheres
- EC Directive 1999/92/EC (ATEX): Improvement of the safety and health protection of workers potentially at risk from explosive atmospheres.

Maintenance

- Low-maintenance as construction and materials are not subject to wear

Function

The attenuation effect of the MK splitters is due to absorption and resonance. The splitters have a mineral wool infill as sound absorbing material. Part of the splitter surface that runs parallel to the airflow is covered with resonating panels. These panels start oscillating due to the sound (resonance) and hence absorb sound energy. Resonance works best in the frequency range of critical fan noise. There is a higher attenuation across a wider frequency range when compared to mere absorption splitters.

Schematic illustration of MK4

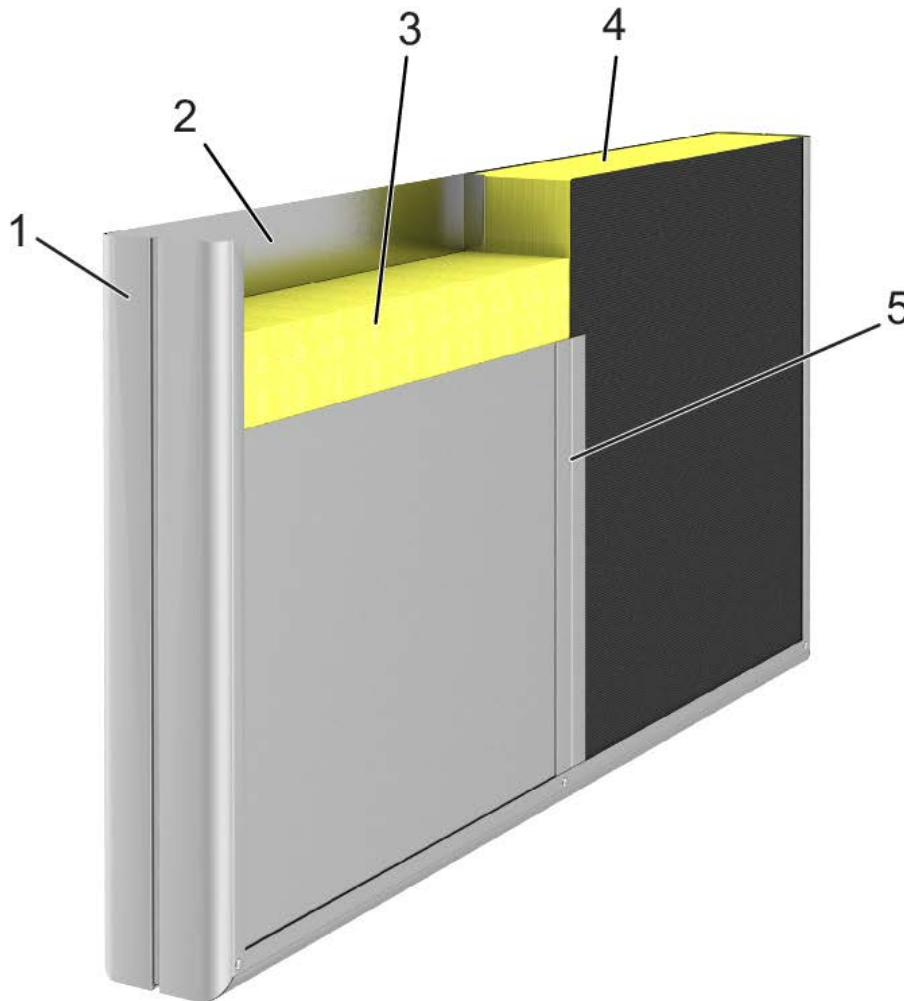

- 1 Splitter frame
- 2 Opposing resonating panels
- 3 Sound absorbing material
- 4 Sound absorbing material faced on both sides with glass fibre fabric
- 5 Centre mullion

Schematic illustration of types MK 8, 9

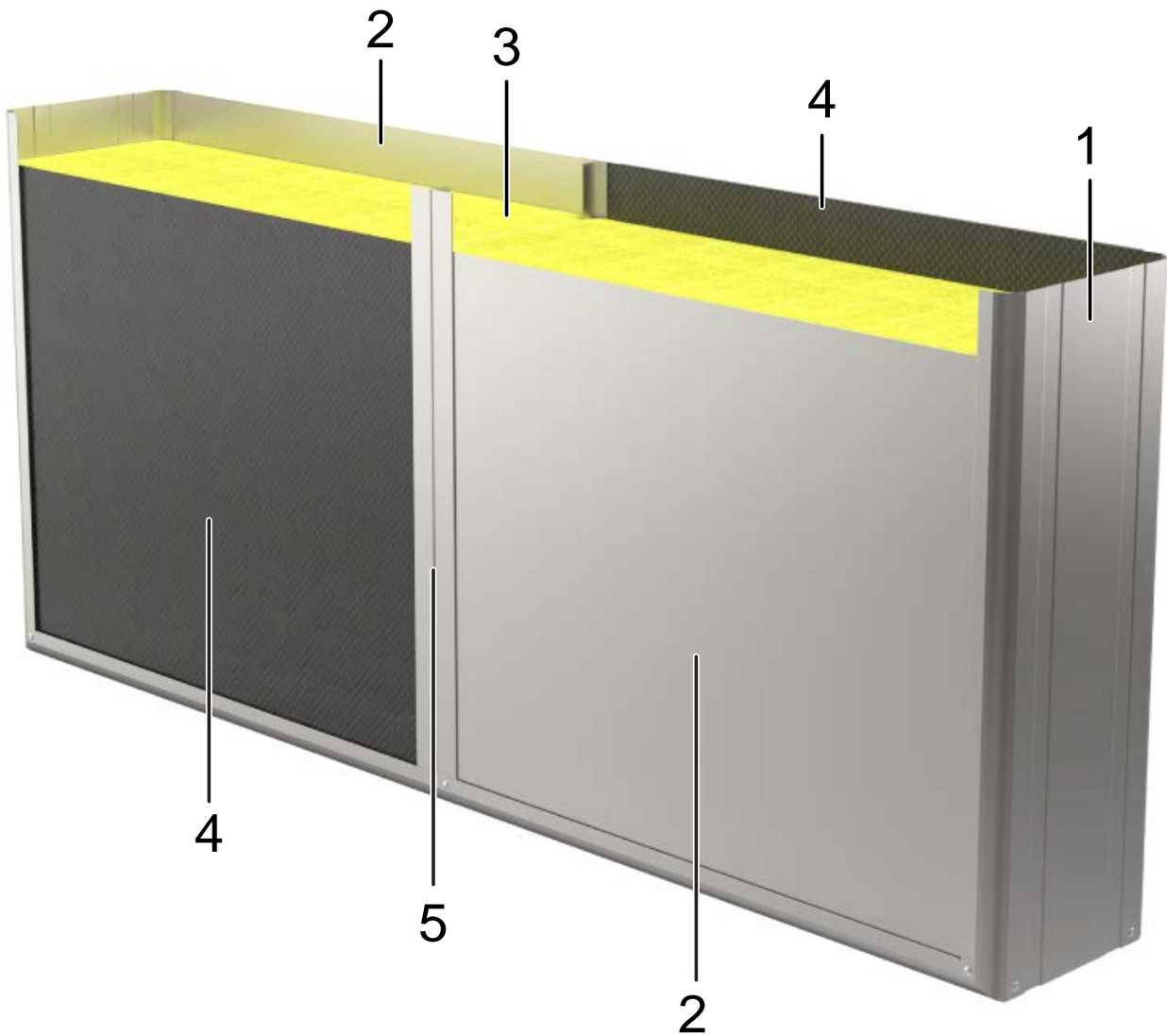

- 1 Splitter frame
- 2 Offset resonating panels
- 3 Sound absorbing material
- 4 Glass fibre fabric (facing)
- 5 Centre mullion

Technical data

Splitter thickness	4", 8", 9"
Nominal sizes (H × L)	6" × 18" – 59" × 98", 18" × 6" – 98" × 59"
Height subdivide	98" – 197" or if H and L > 59"
Length subdivided	98" – 197" or if H and L > 59"
Intermediate sizes	In increments of 0.04"
Operating temperature	Up to 212 °F, variant L up to 572 °F for 8 h max.

The length (L) of sound attenuator splitters refers to the airflow direction.

Quick sizing

Quick sizing tables provide a good overview of the insertion loss and of differential pressures for different airway widths and airflow velocities. Intermediate values can be calculated with our Easy Product Finder design program.

The differential pressures apply to sound attenuators with a height of 3'.

MK4, MS4, insertion loss D_i [dB] and differential pressure Δp_i [in WC]

L	Airway width	Centre frequency f_m [Hz]								v_s [fpm]		
		2	5	10	20	39	79	157	315	0.2	0.4	0.6
20	2	4	9	10	11	19	25	21	16	1969	5709	11024
20	4	3	4	5	8	13	15	11	8	1575	4528	8858
39	2	5	11	18	20	28	34	28	23	2559	7283	14173
39	3	4	8	12	16	23	25	19	15	1969	5512	10827
39	4	4	7	9	13	21	21	15	11	1772	5118	10039
59	2	6	14	26	29	37	42	36	29	3150	8661	17126
59	3	5	11	18	22	32	32	24	19	2362	6299	12402
59	4	4	9	14	19	29	28	19	13	1969	5709	11024
79	2	7	17	34	38	46	> 50	44	36	3740	10236	20079
79	3	6	14	24	29	40	40	29	23	2559	7087	13780
79	4	5	12	19	24	37	34	22	16	2165	6299	12205
98	2	8	20	42	47	> 50	> 50	> 50	43	4331	11811	23229
98	3	7	16	30	35	48	47	34	27	2756	7874	15354
98	4	6	15	24	30	44	41	26	19	2362	6693	13189
118	2	9	22	50	> 50	> 50	> 50	> 50	50	4724	13386	26181
118	3	8	19	35	42	> 50	> 50	39	31	3150	8661	16732
118	4	7	17	28	35	> 50	47	30	22	2559	7283	14370

MK8, MS8, insertion loss D_e [dB] and differential pressure Δp_t [in WC]

L	Airway width	Centre frequency f_m [Hz]								v_s [fpm]		
		2	5	10	20	39	79	157	315	0.2	0.4	0.6
20	2	4	6	18	21	24	18	15	13	4134	11417	22441
20	4	2	4	12	13	15	12	10	8	2165	6102	12008
39	2	6	13	29	34	39	29	20	17	4724	13189	25787
39	3	5	11	24	26	29	22	16	13	2953	8465	16535
39	4	4	9	21	22	24	19	13	11	2559	6890	13583
59	2	8	20	41	46	> 50	41	26	21	5315	14764	28937
59	3	6	16	33	36	40	30	20	16	3346	9449	18504
59	4	5	14	30	32	34	25	17	14	2756	7874	15354
79	2	10	28	> 50	> 50	> 50	> 50	31	26	5906	16339	32283
79	3	8	22	43	47	> 50	39	24	19	3740	10433	20669
79	4	7	20	38	41	43	32	21	17	3150	8661	16929
79	8	3	12	23	22	18	12	10	7	1772	4921	9843
98	2	13	35	> 50	> 50	> 50	> 50	37	30	6496	18110	35433
98	3	10	28	> 50	> 50	> 50	47	28	23	4134	11614	22638
98	4	8	25	47	50	> 50	39	24	19	3346	9449	18504
98	8	4	14	29	28	22	14	11	8	1969	5512	10630
118	2	15	42	> 50	> 50	> 50	> 50	42	34	7087	19685	38780
118	3	11	34	> 50	> 50	> 50	> 50	33	26	4528	12598	24803
118	4	10	30	> 50	> 50	> 50	46	28	22	3740	10433	20276
118	8	5	17	35	34	26	16	13	10	2165	5906	11614

MK9, MS9, insertion loss D_e [dB] and differential pressure Δp_t [in WC]

L	Airway width	Centre frequency f_m [Hz]								v_s [fpm]		
		2	5	10	20	39	79	157	315	0.2	0.4	0.6
20	3	2	6	14	16	18	14	12	12	2953	8465	16535
20	4	2	5	12	13	15	11	10	11	2559	6890	13583
39	3	6	11	24	25	29	21	15	15	3543	9646	19094
39	4	5	10	21	22	25	17	13	14	2756	7874	15354
39	8	2	7	14	12	10	6	7	9	1575	4528	8661
59	3	9	17	34	35	41	28	19	18	3937	11024	21457
59	4	8	15	31	31	34	23	16	16	3150	8858	17323
59	8	3	11	20	17	14	9	10	10	1772	4921	9646
79	3	13	22	44	45	> 50	34	22	22	4331	12205	23819
79	4	11	20	40	39	44	29	20	19	3543	9843	19291
79	8	4	14	26	23	18	12	12	12	1969	5512	10630
98	3	16	27	> 50	> 50	> 50	41	25	25	4921	13386	26378
98	4	13	25	49	48	> 50	35	23	22	3937	10827	21260
98	8	5	18	33	28	22	15	15	13	2165	5906	11614
118	3	19	33	> 50	> 50	> 50	48	29	28	5315	14567	28740
118	4	16	30	> 50	> 50	> 50	41	26	25	4331	11811	23031
118	8	6	21	39	34	26	17	17	15	2362	6496	12598

Specification text

This specification text describes the general properties of the product. Texts for variants can be generated with our Easy Product Finder design program.

Sound attenuator splitters used for the reduction of fan noise and air-regenerated noise in air conditioning systems. Attenuation effect due to absorption and resonance. Energy-saving as well as hygiene tested.

Installation kit consists of an aerodynamically profiled frame (bullnose radius of 0.8"), sound absorbing material and resonating panels.

The splitter frame reduces pressure losses and air-regenerated noise. The special profile helps to reduce the weight and increase the rigidity of the splitters. Frame edges with bullnose to protect the sound absorbing infill.

Insertion loss and sound power level of the air-regenerated noise tested to ISO 7235.

Meets the hygiene requirements of VDI 6022, VDI 3803 Part 1 and DIN 1946 Part 4.

For use in areas with potentially explosive atmospheres (ATEX), zones 1, 2, 21 and 22 (outside) according to Directive 1999/92/EC.

Special features

Resonating panels ensure increased insertion loss in the frequency range of critical fan noise

- Energy savings due to aerodynamically formed splitter frame
 - Up to 30 % lower differential pressure
- Hygiene tested and compliant with VDI 6022
- Multi-section construction available for large dimensions

Materials and surfaces

- Splitter frames, centre mullion and resonating panels made of galvanised sheet steel 1.0917 or stainless steel 1.4301
- Expanded metal facing made of galvanised steel 1.0917
- Perforated metal facing made of stainless steel 1.4301
- Absorption material is mineral wool
 - To EN 13501, fire rating Class A1, non-combustible
 - RAL quality mark RAL-GZ 388
 - Biosoluble and hence non-hazardous to health according to the German TRGS 905 (Technical Rules for Hazardous Substances) and EU Directive 97/69/EC

- Faced with glass fibre fabric as a protection against erosion from airflow velocities of up to 3937 fpm
- Inert to fungal and bacterial growth according to EN 846

Construction

Half of the splitter is covered by a resonating panel

- F: Glass fibre fabric
- L: glass fibre fabric faced with expanded metal as an additional mechanical protection for the sound absorbing material

Materials and surfaces

- No entry: Galvanised steel 1.0917
- A2: Stainless steel 1.4301
 - Construction L: Glass fibre fabric with perforated metal facing as an additional mechanical protection for the sound absorbing material
- P1: Powder-coated RAL 7001, silver grey

Technical data

- Splitter thickness: 4", 8", 9"
- Dimensions: 6" × 18" – 59" × 98", 18" × 6" – 98" × 59"
- Height subdivided: up to 197"
- Length subdivided: up to 197"
- Intermediate sizes: in increments of 0.04"
- Operating temperature: up to 212 °F, variant L up to 572 °F for 8 h max.

The length (L) of splitter sound attenuators refers to the airflow direction.

- B [in]
- H [in]
- L (in airflow direction) [in]
- q_v (cfm)
- D_e At 250 Hz [dB]
- Δp_{st} [in WC]

Order code

MK - ... - F - A2 / 8 × 24 × 59
 1 2 3 4 5 6 7

1 Type

MK Sound attenuator splitter with resonating panels

No entry required: Galvanised steel 1.0917

A2 Stainless steel 1.4301

P1 Powder-coated in RAL 7001, silver grey

2 Variant

No entry required: TROX standard variants

ACC Connecting material: U-sheets, clamp sheets

5 Splitter thickness T [in]

4, 8, 9

3 Splitter surface

F Glass fibre fabric

L Glass fibre fabric and expanded metal

6 Height H [in]

6 – 197

4 Material

7 Length L in airflow direction [in]

6 – 197

Order example: MK-F-A2/4×59×39

Splitter surface	Glass fibre fabric
Material	Stainless steel 1.4301
Splitter thickness	4"
Height	59"
Length	39"

Assembly material SDK

To be ordered separately if splitters are to be subdivided by others.

SDK - A2 / 8 / 2
 1 2 3 4

1 Type

SDK Accessories for sound attenuator splitters

4 With 2 U-sheets

8 With 2 U-sheets

9 With 2 U-sheets

12 With 2 U-sheets

2 Material

No entry: galvanised steel (1.0917)

A2 Stainless steel (1.4301)

P1 Powder-coated RAL 7001 (galvanised steel (1.0917))

3 Splitter thickness T [in]

No entry: without U-sheets

4 No. of clamp sheets for the joints

No entry: H or L ≤ 30" without clamp sheets

2 H or L 30" – 39": 2 clamp sheets

4 H or L ≥ 39": 4 clamp sheets

Order example: SDK-A2/8/2

Material	Stainless steel (1.4301)
Splitter Thickness	8", with 2 U-sheets
No. of clamp sheets	2

Dimensions

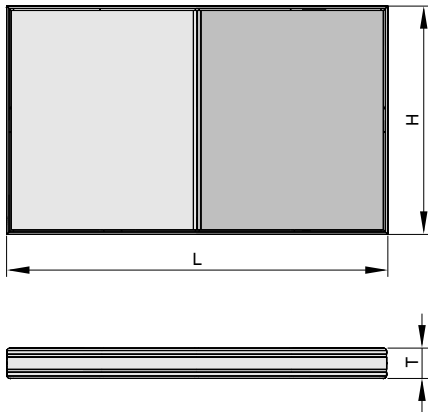

- H: 6" – 98"
- L: 20", 30", 39", 49", 59", 69", 79", 89", 98"
- Intermediate sizes of H and L are possible: 6" – 98" in increments of 0.04"
- Undivided construction: H + L 24" min., 157" max., 220 lbs max.
- Size limit for H or L: If one dimension is greater than 59", the other one must not exceed 59"
- Height or length subdivided is possible for sizes 98" – 197"

The total weight for intermediate sizes can be generated with our Easy Product Finder design program.

Weights

MK 4 – Glass fibre fabric (-F)

H	L									
	20	30	39	49	59	69	79	89	98	
20	7	11	13	15	18	22	24	26	29	
30	11	13	18	20	24	29	33	35	40	
39	13	18	22	26	33	37	42	46	51	
49	15	20	26	33	40	44	51	60	66	
59	18	24	33	40	46	53	64	71	77	
69	22	29	37	44	53	X	X	X	X	
79	24	33	42	51	60	X	X	X	X	
89	26	37	46	55	66	X	X	X	X	
98	29	40	51	62	71	X	X	X	X	

X = subdivided construction

MK 100 – Glass fibre fabric and expanded metal (-L)

H	L									
	20	30	39	49	59	69	79	89	98	
20	9	11	15	18	22	26	29	33	35	
30	11	18	22	26	31	35	40	44	49	
39	15	22	26	33	42	46	53	57	64	
49	18	26	33	42	49	57	64	75	82	
59	22	31	40	49	57	66	79	88	97	
69	26	35	46	57	66	X	X	X	X	
79	29	42	53	64	75	X	X	X	X	
89	33	46	57	71	84	X	X	X	X	
98	35	51	64	77	90	X	X	X	X	

X = subdivided construction

**MK 4 – Glass fibre fabric and perforated sheet metal (-L-A2)**

H	L									
	20	30	39	49	59	69	79	89	98	
20	11	15	18	22	26	31	35	40	44	
30	15	20	26	31	37	44	51	55	62	
39	18	26	33	40	51	57	66	73	79	
49	22	31	40	53	62	71	79	93	101	
59	26	37	51	62	73	84	99	110	121	
69	31	44	57	71	84	X	X	X	X	
79	35	51	66	79	95	X	X	X	X	
89	40	55	73	88	106	X	X	X	X	
98	44	62	79	97	115	X	X	X	X	

X = subdivided construction

MK 8 – Glass fibre fabric (-F)

H	L									
	20	30	39	49	59	69	79	89	98	
20	11	15	20	24	29	33	37	40	44	
30	15	22	26	31	37	44	51	55	62	
39	20	26	33	40	51	57	64	71	77	
49	24	31	40	51	60	68	77	90	99	
59	29	37	49	60	71	79	95	106	115	
69	33	44	57	68	79	X	X	X	X	
79	37	51	64	77	90	X	X	X	X	
89	42	55	71	86	99	X	X	X	X	
98	46	62	77	93	110	X	X	X	X	

X = subdivided construction

MK 8 – Glass fibre fabric and expanded metal (-L)

H	L									
	20	30	39	49	59	69	79	89	98	
20	13	18	22	26	31	37	42	46	51	
30	18	24	31	37	44	51	57	64	71	
39	22	31	37	46	57	66	75	82	90	
49	26	37	46	60	71	79	90	106	115	
59	31	44	57	68	82	95	112	123	134	
69	37	53	66	79	95	X	X	X	X	
79	42	57	75	90	106	X	X	X	X	
89	46	64	82	99	117	X	X	X	X	
98	53	71	90	110	130	X	X	X	X	

X = subdivided construction

MK 8 – Glass fibre fabric and perforated sheet metal (-L-A2)

H	L									
	20	30	39	49	59	69	79	89	98	
20	15	20	26	31	35	42	49	53	60	
30	20	29	35	42	51	60	68	75	84	
39	26	35	46	55	68	77	88	97	106	
49	31	42	55	68	82	95	106	123	134	
59	35	51	66	82	95	110	130	146	159	
69	44	60	77	95	110	X	X	X	X	
79	49	68	88	106	126	X	X	X	X	
89	55	75	97	119	139	X	X	X	X	
98	60	84	106	130	154	X	X	X	X	

X = subdivided construction

MK 9 – Glass fibre fabric (-F)

H	L									
	20	30	39	49	59	69	79	89	98	
20	13	18	22	26	31	35	40	44	49	
30	18	24	29	35	42	49	55	62	66	
39	22	29	37	44	55	62	71	77	86	
49	26	35	44	55	66	75	86	99	108	
59	31	42	55	66	77	88	106	117	126	
69	37	51	62	75	88	X	X	X	X	
79	42	55	71	86	99	X	X	X	X	
89	46	62	77	95	110	X	X	X	X	
98	51	68	86	104	121	X	X	X	X	

X = subdivided construction

MK 9 – Glass fibre fabric and expanded metal (-L)

H	L									
	20	30	39	49	59	69	79	89	98	
20	13	20	24	29	35	40	46	51	55	
30	20	26	33	40	46	55	62	71	77	
39	24	33	42	51	64	73	82	90	99	
49	29	40	51	64	75	88	97	115	123	
59	35	46	62	75	88	101	121	134	146	
69	42	57	73	88	101	X	X	X	X	
79	46	64	82	97	115	X	X	X	X	
89	51	71	90	108	128	X	X	X	X	
98	57	77	99	119	141	X	X	X	X	

X = subdivided construction

MK 9 – Glass fibre fabric and perforated sheet metal (-L-A2)

H	L									
	20	30	39	49	59	69	79	89	98	
20	15	22	29	33	40	46	53	57	64	
30	22	31	37	46	55	64	73	82	88	
39	29	37	49	60	73	84	95	104	115	
49	33	46	60	75	88	101	115	132	146	
59	40	55	73	88	104	119	141	154	170	
69	46	66	84	101	119	X	X	X	X	
79	53	73	95	115	134	X	X	X	X	
89	60	82	104	128	150	X	X	X	X	
98	64	90	115	139	165	X	X	X	X	

X = subdivided construction

Installation details

Installation and commissioning

- Follow the installation manual and comply with the general codes of good practice in order to achieve the given performance data
- Up to height H = 47", length L = 59" and 88 lbs: any installation orientation, but we recommend upright installation of splitters
From height H = 47": upright installation only
- The length (L) of sound attenuator splitters and splitter sound attenuators refers to the airflow direction; be sure to note how width, height and length are defined, particularly in case of a vertical airflow

- A turbulent airflow may cause damage to the splitters
 - A straight upstream section is required upstream of the sound attenuator
 - The recommended minimum upstream section depends on the change of direction, change of cross-section and splitter arrangement
- Installation in ducts outside closed rooms requires sufficient protection against the effects of weather

Upstream conditions after bends, junctions or a narrowing or widening of the duct, vertical upstream section, splitters upright

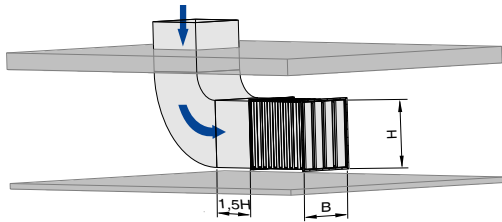

B Width of the sound attenuator
H Height of the sound attenuator and the splitters

Upstream conditions after bends, junctions or a narrowing or widening of the duct, vertical upstream section, splitters horizontal

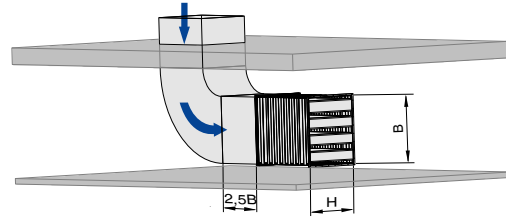

B Width of the sound attenuator
H Height of the sound attenuator and the splitters
Horizontal installation only for splitters up to height 47"

Upstream conditions after bends, junctions or a narrowing or widening of the duct, horizontal upstream section, splitters upright

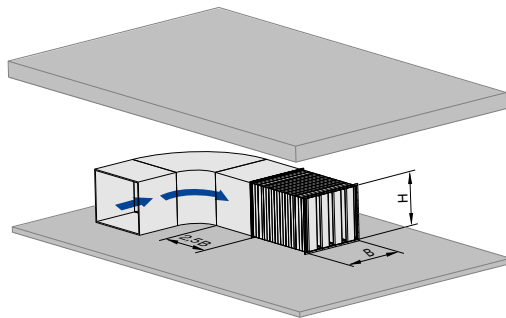

B Width of the sound attenuator
H Height of the sound attenuator and the splitters

Upstream conditions after bends, junctions or a narrowing or widening of the duct, horizontal upstream section, splitters horizontal

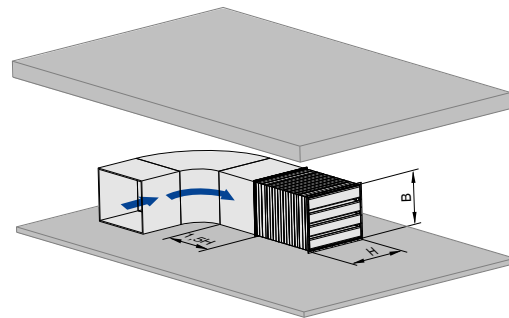

B Width of the sound attenuator
H Height of the sound attenuator and the splitters
Horizontal installation only for splitters up to height 47"

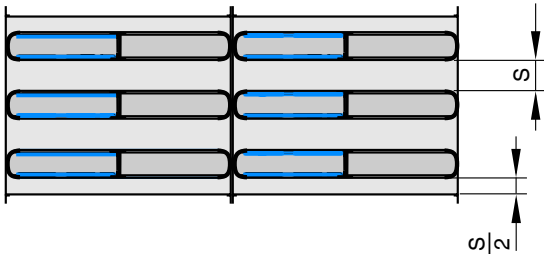

MK4: Opposing resonating panels

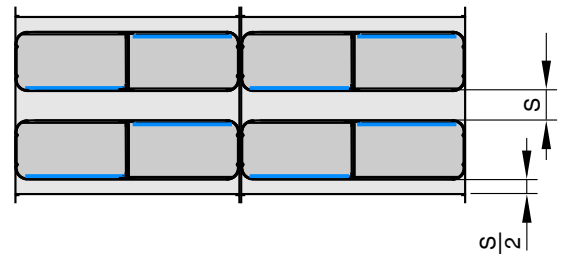

MK8, MK9: Offset resonating panels

Accessories – variant ACC

- U-sheets/clamp sheets to join subdivided attenuator splitters (included with subdivided splitter constructions)
- U-sheets and clamping sheets (ACC) for previously provided single splitters that are to be connected
 - Made of galvanised sheet steel 1.0917 or stainless steel 1.4301
 - Number according to division rule for height or length subdivided splitters
 - Specification of the total dimensions is necessary for the delivery of the recommended number of pieces
- Fixing material for connecting the U-sheets and clamp sheets to the sound attenuator to be provided by others

Number of clamp sheets per splitter joint:

H or L ≤ 30": without clamp sheet

H or L 30" – 39": 1 clamp sheet on each side

H or L > 39": 2 clamp sheets on each side recommended

Number of U-sheets per splitter joint: 2

Follow the instructions in the installation manual.

A

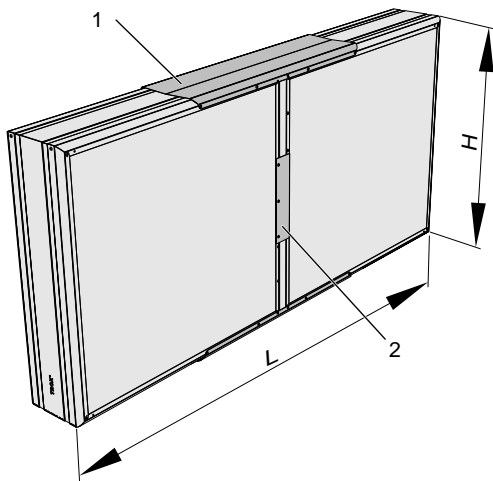

B

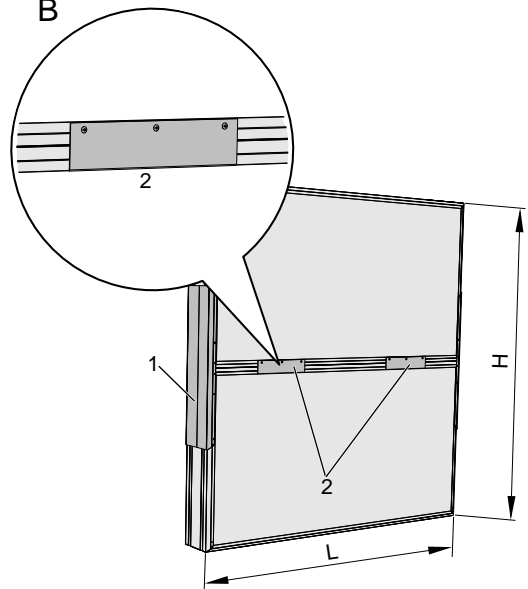

A Construction with length subdivided

- H 39 × L 157 with 2 U-sheets, 2 clamp sheets B

Height subdivided

- H 79 × L 98 with 2 U-sheets, 4 clamp sheets

1

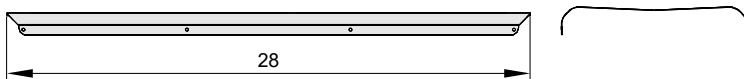

2

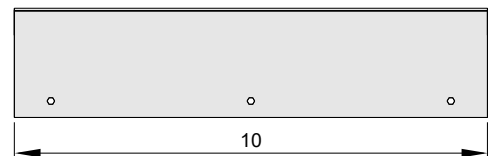

1 U-sheet

2 Clamp sheet

Nomenclature

L [in] Length of sound attenuator including spigot (always in airflow direction)	S [in] Airway width
L₁ [in] Length of part 1 of a splitter sound attenuator with the length subdivided	m [lbs] Weight
L₂ [in] Length of part 2 of a splitter sound attenuator with the length subdivided	f_m [Hz] Octave band centre frequency
B [in] Sound attenuator width and duct width	D_o [dB] Insertion loss
B₁ [in] Width of part 1 of a splitter sound attenuator with the width subdivided	q_v [cfm] Volume flow rate
B₂ [in] Width of part 2 of a splitter sound attenuator with the width subdivided	Δp_t [in WC] Total differential pressure
H [in] Sound attenuator height and duct height (upright splitters)	v_s [fpm] Airflow velocity
T [in] Splitter thickness	Lengths All lengths are given in inches [in] unless stated otherwise.
	Measured values All sound power levels are based on 1 pW. All values were measured in a TROX lab and to EN ISO 7235. Intermediate values may be achieved by interpolation. Lab measurements exceeding 50 dB are indicated as 50 dB, based on practical conditions.