



TROX GmbH

Heinrich-Trox-Platz
47504 Neukirchen-Vluyn,
Ger-many
Germany
Phone: +49 (0) 2845 2020
Fax: +49 (0) 2845 202265 E-
mail: trox@trox.de Internet:
http://www.trox-technik.com



TFM

Particulate filter modules for ceilings

Product overview

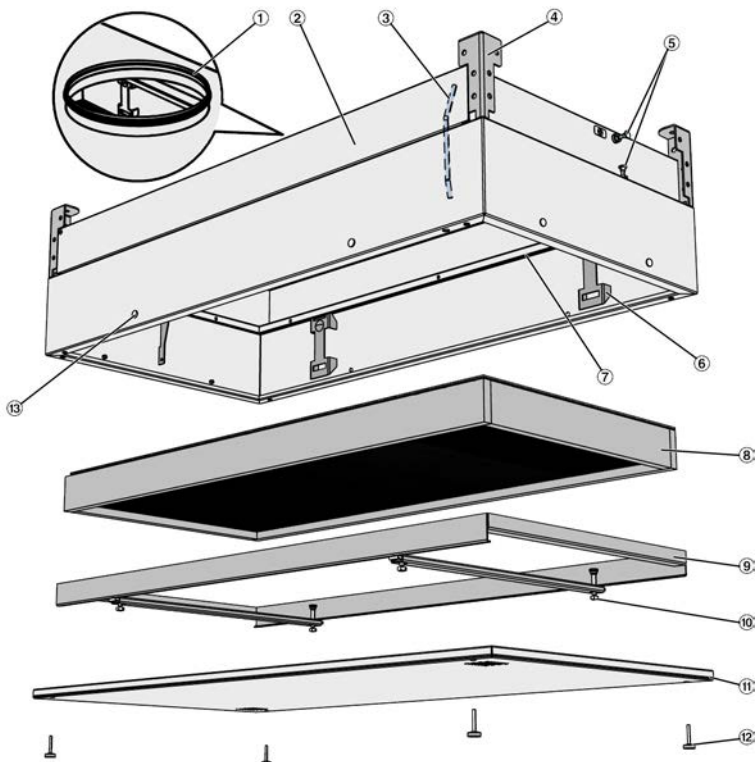

Fig. 1: Schematic illustration, e. g. TFM

- | | | | |
|---|------------------------------|---|---------------------------------------|
| ① | Spigot with lip seal | ⑧ | Filter |
| ② | Casing | ⑨ | Clamping frame for the filter element |
| ③ | Internal measuring tube | ⑩ | Clamping screw |
| ④ | Suspension | ⑪ | Diffuser face |
| ⑤ | Pressure measurement point | ⑫ | Screw fixing diffuser face |
| ⑥ | Bracket for tensioning frame | ⑬ | Sealing plug for connecting holes |
| ⑦ | Test groove | | |

Important notes

Information on the installation manual

This manual enables operating or service personnel to correctly install the product described below and to use it safely and efficiently.

It is essential that these individuals read and fully understand this manual before starting any work. The basic prerequisite for safe working is to comply with the safety notes and all instructions in this manual.

The local regulations for health and safety at work and general safety regulations also apply.

Correct use

Type TFM particulate filter module for ceilings is used as a final filter for the separation of suspended particles and for air distribution.

The TFM can be used in the supply air and extract air systems of ventilation and air conditioning systems. They are suitable for the fitting of Mini Pleat filter panels for the separation of suspended particles, to ensure critical air cleanliness and meet demanding hygiene requirements.

It is important that you comply with any national hygiene regulations when you install, commission or use the particulate filter module.

Incorrect use



WARNING!

Danger due to incorrect use!

Incorrect use of the unit can lead to dangerous situations.

Never use the unit:

- in areas with potentially explosive atmospheres
- in humid rooms
- in rooms with aggressive or dust-laden air

Limitation of liability

The information in this manual has been compiled with reference to the applicable standards and guidelines, the state of the art, and our expertise and experience of many years.

The manufacturer does not accept any liability for damages resulting from:

- Non-compliance with this manual
- Incorrect use
- Operation or handling by untrained individuals
- Unauthorised modifications
- Technical changes
- Use of non-approved replacement parts

The actual scope of delivery may differ from the information in this manual for bespoke constructions, additional order options or as a result of recent technical changes.

The obligations agreed in the order, the general terms and conditions, the manufacturer's terms of delivery, and the legal regulations in effect at the time the contract is signed shall apply.

We reserve the right to make technical changes.

Defects liability

For details regarding defects liability please refer to Section VI, Warranty Claims, of the Delivery and Payment Terms of TROX GmbH.

The Delivery and Payment Terms of TROX GmbH are available at www.troxtechnik.com.

Qualified staff

HVAC technician

HVAC technicians are individuals who have sufficient professional or technical training in the field they are working in to enable them to carry out their assigned duties at the level of responsibility allocated to them and in compliance with the relevant guidelines, safety regulations and instructions. HVAC technicians are individuals who have in-depth knowledge and skills related to HVAC systems; they are also responsible for the professional completion of the work under consideration.

HVAC technicians are individuals who have sufficient professional or technical training, knowledge and actual experience to enable them to work on HVAC systems, understand any potential hazards related to the work under consideration, and recognise and avoid any risks involved.

Properly trained person

Properly trained persons are trained individuals who understand any potential hazards related to the work under consideration, and who recognise and avoid any risks involved. Training is provided by the HVAC contractor when the system is handed over.

Properly trained persons are responsible for cleaning the unit, and for carrying out functional tests, regular checks and smaller adjustments.

Personal protective equipment

Personal protective equipment must be worn for any work in order to reduce health or safety hazards to the minimum.

The appropriate protective equipment for a job must be worn for as long as the job takes.

Industrial safety helmet



Industrial safety helmets protect the head from falling objects, suspended loads, and the effects of striking the head against stationary objects.

Light respiratory protection



Light respiratory protection is used to provide protection from harmful dusts.

Protective gloves



Protective gloves protect hands from friction, abrasions, punctures, deep cuts, and direct contact with hot surfaces.

Safety shoes



Safety shoes protect the feet from crushing, falling parts and prevent slipping on a slippery floor.

Supply package, transport and storage

The supply package for the particulate filter module includes:

- TFM casing
- Diffuser face
- Filter element (optional)

Transport



CAUTION!

Danger of injury from sharp edges, sharp corners and thin sheet metal parts!

Sharp edges, sharp corners and thin sheet metal parts may cause cuts or grazes.

- Be careful when carrying out any work.
- Wear protective gloves, safety shoes and a hard hat.

Use only lifting and transport gear designed for the required load. Always secure the load against tipping and falling.

Upon delivery, carefully remove the packaging and check the unit for transport damage and completeness.

Storage

Please note:

- Store the unit only in its original packaging
- Protect the unit from the effects of weather
- Protect the unit from humidity, dust and contamination
- Storage temperature: 14 °F to 122 °F.
- Relative humidity: 95 % max., no condensation

Assembly

General information

- Fix the unit only to load-bearing ceilings.
- Load suspension systems only with the weight of the unit. Adjacent components and connecting ducts must be supported separately.
- Do not unpack the diffuser face and any filter element until you are ready to install them.



NOTICE!

Possible malfunction due to a damaged casing

If the casing has been damaged, unfiltered (contaminated) air may leak.

Do not drill any holes into the casing.



If there is a lengthy break between installation and commissioning, cover all openings of the casing (e.g. with plastic) to protect the interior and avoid cumbersome cleaning procedures at the time of commissioning.

Fixing to the ceiling slab

Personnel:

- HVAC technician

Protective equipment:

- Industrial safety helmet
- Protective gloves
- Safety shoes

If possible, install the device before fixing the ceiling tiles; if this is not possible, remove the adjacent ceiling tiles.

The TFM can weigh up to 77 lbs, depending on the construction. Use only approved and adequately sized suspension systems. Fixing material is not included in the supply package.

Only work in pairs; preferably use a lift.



DANGER!

Danger of death from the fall of suspended loads!

- Only use fixing materials designed for the required load.
 - Use all hanging brackets supplied.
 - Stand clear of suspended loads, unless properly secured.
 - Check secure fixing after installation.
- ▶ Remove the clamping frame from the casing. To do so, loosen the clamping screws (Fig. 1/5), then remove the clamping frame (Fig. 1/4). Remove and dispose of the spacers; keep the clamping frame as you will need it again later.

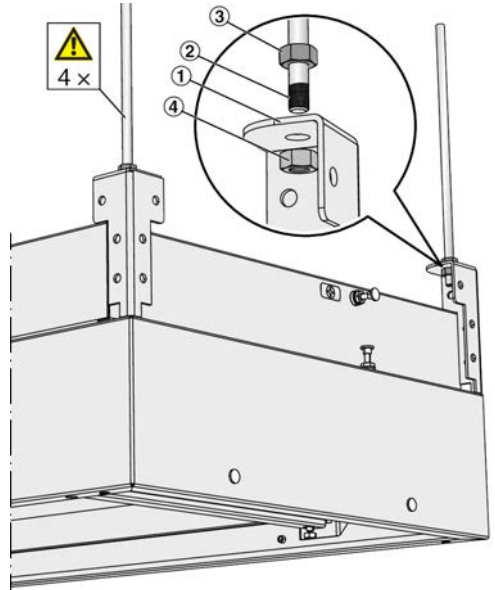

Fig. 2: Fixing

- Suspension lug with drilled hole \varnothing 0.5 in
 - Threaded rod
 - Lock nut
 - ④ Nut
- ▶ Fix any suspension elements, e.g. threaded rods (Fig. 2/2), to the ceiling.
 - ▶ Start by suspending the TFM casing on three suspension lugs (Fig. 2/1); ensure that the casing is horizontal, fix the nuts accordingly (Fig. 2/4), then use the locknuts (Fig. 2/3) to secure the suspended casing.

Loads imposed on the casing may impair the function of the unit. Be sure to install the unit without torsion.
 - ▶ Fix the fourth threaded rod without changing the position of the TFM casing and secure it with a locknut.

Connecting to a ceiling tile

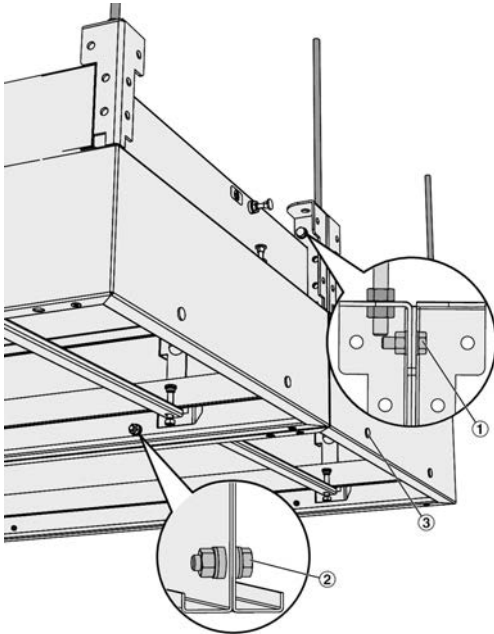

Fig. 3: TFM ceiling tile assembly

- ① Screw M8, U-discs (2x) and nut
- ② Screw M8, sealing washer (2x), U-discs (2x) and nut
- ③ Sealing plug

TFM modules can be connected underneath each other to a ceiling tile. For this, the modules are screwed with screw connections, accessories of assembly kit article no. A00000067468.

Note: At suspension points where several ceiling modules (2...4) are connected with one another, these can be fixed to the ceiling slab with just one suspension system as long as the modules were connected with one another correctly. However, the increased load on the suspension system must be taken into account.

- 1. ▶ Remove the sealing plug on the connecting sides of both modules.
- 2. ▶ Install the other casing in accordance with steps 1-4 beside the first casing.

- 3. ▶ Screw the module to the casing and the suspension system using the optional assembly kit.

Ceiling systems

Particulate filter modules are usually installed in suspended ceilings. The flush connection to a ceiling slab is shown below.

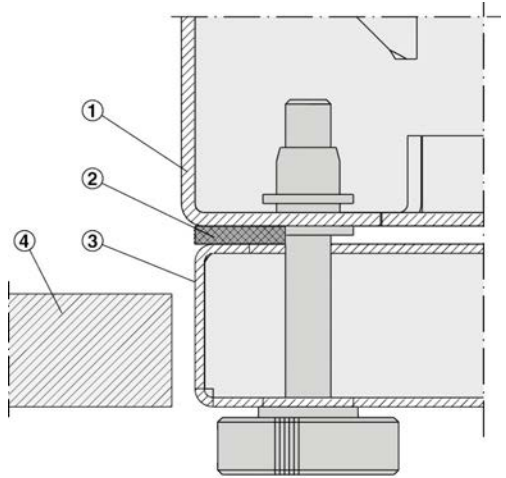

Fig. 4: Flush installation in continuous ceilings

- ① TFM casing
- ② Seal
- ③ Diffuser face
- ④ Plasterboard ceiling

Connecting the ductwork

Type TFM particulate filter modules for ceilings are supplied with different spigots as follows:

- Top entry circular spigot

The spigot has a lip seal and is suitable for circular ducting in accordance with EN 1506 or EN 13180.

Connect the duct in such a way that the connection is tight.

To protect the filter elements once installed as much as possible from excessive contamination, proceed as follows when you install the ventilation system:

- Keep the ducts clean when you install them.
- If you have to interrupt the installation procedure, protect all openings from the ingress of dust.
- If necessary, clean the ducts before you commission the ventilation system.

Commissioning

General information

Before you start commissioning:

- Check that the filter casings are correctly seated.
- Remove protective film, if any.
- Ensure that all filter casings are clean and free from residues and foreign matter.
- Prime the ventilation and air conditioning system for 24 hours before you insert the filter element.

Volume flow rate balancing

To adjust the ventilation and air conditioning system, you first have to carry out volume flow rate balancing for each particulate filter module. Volume flow rate balancing is required before initial commissioning.

Inserting filters

- Do not unpack filter elements until you are ready to install them.
- Do not touch the filter, hold it by the edge only.
- Check filter elements for any damage; replace damaged filter elements.
- Insert only suitable Mini Pleat filter elements with a flat seal or fluid seal.

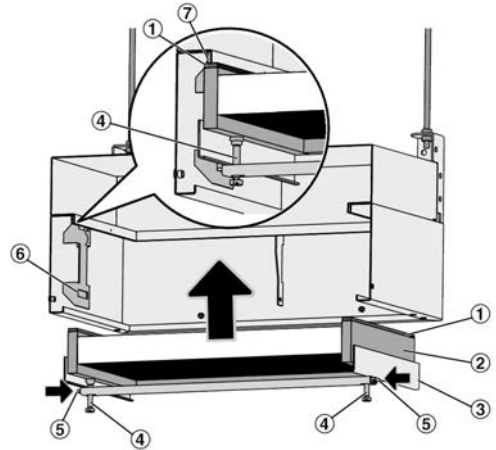

Fig. 5: Inserting filters

1. ▶ Remove the clamping frame (Fig. 5/3) from the particulate filter module. To do so, loosen the clamping screws (Fig. 5/4), then press the release buttons (Fig. 5/5) in; remove spacers, if any (spacers are used to fix the clamping frame during transport of the unit).

! NOTICE!

Do not damage the filter.

Handle filter elements with care and hold them only by the edges.

2. ▶ Set the filter element (Fig. 5/2) with the seal (Fig. 5/1) facing upwards into the clamping frame.

3. ▶ Push the clamping frame with the filter element into the casing. Ensure that the release buttons snap into the recesses on both sides (Fig. 5/6).
4. ▶ Turn in the clamping screws evenly so that the filter is pressed against the test groove (Fig. 5/7); max. torque 2 Nm.
5. ▶ Once you have inserted the filter element, check that there are no leaks, ☞ *'Leakage test on an installed filter' on page 9.*
6. ▶ Installing the diffuser face.

Installing the diffuser face

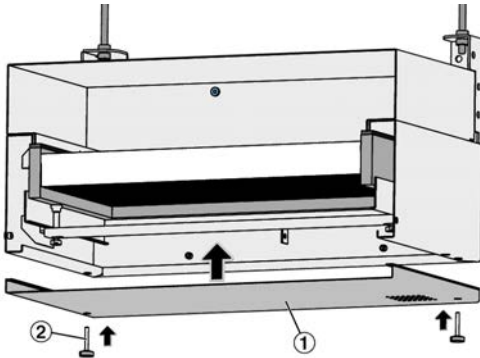

Fig. 6: TFM assembly diffuser face

- ▶ Set the diffuser face (Fig. 6/1) onto the filter casing and fix it with the knurled screws (Fig. 6/2).



CAUTION!

Risk of injury from a falling diffuser face!

Ensure that the diffuser face is correctly seated and secured.

Maintenance

Maintenance applies mainly to the filter element. Check the filter regularly and replace it, if necessary.

The service life of a filter depends mainly on how polluted the air is. Check the filter in intervals that are short enough such that you can anticipate any defects or problems before they actually occur.

Replace the filter immediately if any of the following is true:

- The defined final differential pressure has been reached.
- Hygiene problems (micro-organisms, fungal spores, odours, etc.)
- Filter defects (particle count has been exceeded)
- The maximum filter usage time has been reached (8 years, to VDI 3803, part 4).



You may replace a filter even before the defined final differential pressure has been reached if it is more economic.

Removing the diffuser face

Some maintenance jobs, such as sealing integrity testing, leakage testing, filter changes or cleaning, require you to remove the diffuser face.

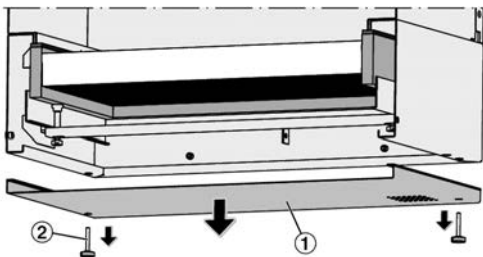

Fig. 7: Removing the diffuser face

- ▶ Unscrew the knurled screws (Fig. 7/2) and remove diffuser face (Fig. 7/1).

Leakage test on an installed filter

A functional test of the filter system is required to ensure that there are no leaks and that the filter element is without any defects (no small holes on the filter frame or on the seal, no leaks at the filter frame).

1. ▶ Remove the diffuser face, see 'Removing the diffuser face' on page 9.

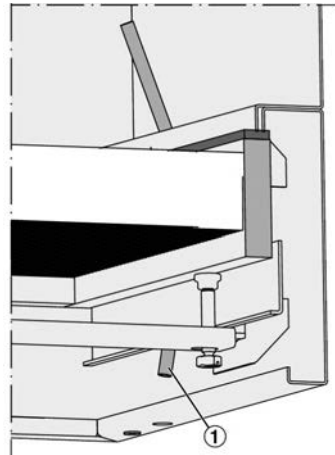

Fig. 8: Measuring tube

- ① Measuring tube $\varnothing 0.3 \times 0.1$ in
2. ▶ Open the measuring tube by removing the cheese head screw.
3. ▶ Measure the particle concentration on the upstream side to ISO 14644-3 B6.
4. ▶ Measure the particle concentration on the downstream side to ISO 14644-3 B6.
If there is a leak, seal it; then test for leaks again.
5. ▶ Close the measuring tube by inserting the cheese head screw.
6. ▶ Re-install the diffuser face.

Sealing integrity test

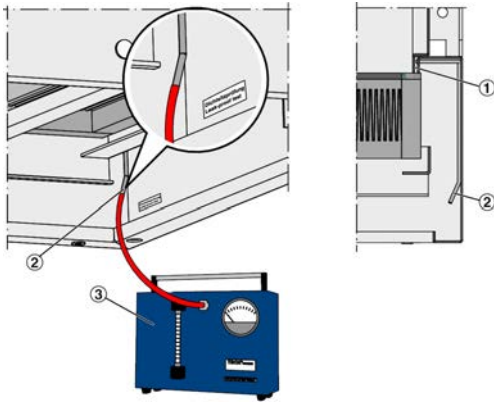

Fig. 9: Sealing integrity test

The casing is fitted with a sealing integrity test facility. Sealing integrity is tested with a sealing integrity test device (see operating manual).

1. ▶ Connect the sealing integrity test device (Fig. 9/3) to the connection point on the filter (Fig. 9/2).
2. ▶ Apply at least 8.04 in wg to the test groove (Fig. 9/1).
3. ▶ Check the leakage rate on the flow rate meter of the sealing integrity test device.
 - ⇒ The value must not exceed 0.003% of the nominal volume flow rate.

If this value is exceeded, adjust the clamping screws or the clamping frame; also check the seal, test groove and filter element for damage. Then repeat the sealing integrity test.

Differential pressure measurement

The initial differential pressure for TROX filters is given on the label on the filter frame.

There are two ways to measure the differential pressure:

Permanent measurement: Continuous differential pressure measurement and monitoring of the final differential pressure. This is done with a static differential pressure measuring device (Fig. 10/1), e.g. TROX MD-UT, MD-APC or MD-DPC, using the pressure measurement points (Fig. 10/2) at the side or on the top of the casing.

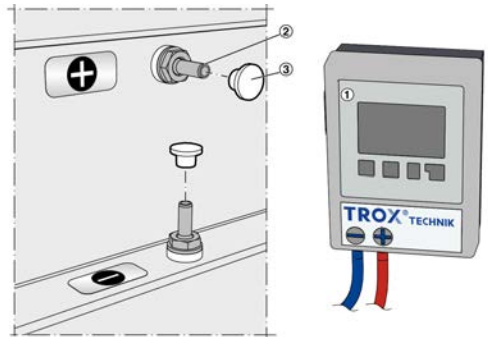

Fig. 10: TROX MD-DPC connection

Connecting a stationary measuring device

- Plus (+) - to the 'Plus' measurement point (+)
- Minus (-) - to the 'Minus' measurement point (-)

Temporary measurement: Temporary differential pressure measurement with a mobile measurement device connected to the internal measuring tube (Fig. 10). For this, you have to remove the diffuser face, ↗ 9.

Connecting a mobile measuring device

- Plus (+) - to the internal measuring tube (Fig. 8/1)
- Minus (-) - Don't connect; the differential pressure is measured against the room pressure.

Re-attach the plugs (Fig. 10/3) after the measurement.

Changing the filter

Personnel:

- Properly trained person

Protective equipment:

- Industrial safety helmet
- Light respiratory protection
- Protective gloves

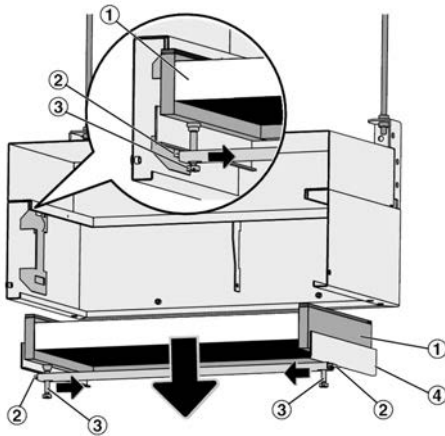

Fig. 11: Filter change

Before you start changing filters, switch off the air conditioning system.

- ▶ Remove the diffuser face, see *'Removing the diffuser face'* on page 9.
- ▶ Remove the clamping frame. To do so, loosen the clamping screws (Fig. 11/3) and press the release buttons (Fig. 11/2) in. Remove the clamping frame (Fig. 11/4) with the filter element.
- ▶ Remove the dust-laden filter (Fig. 11/1) from the clamping frame, put it into a plastic bag and dispose of it properly, see *'Disposal'* on page 11.
- ▶ If the filter casing is dirty, clean and disinfect it see *'Cleaning the filter casing'* on page 12.

- ▶ Insert a new filter element, reinstall the clamping frame including the filter, and fix the diffuser face again, see *'Chapter 6 'Commissioning'* on page 7.

Disposal



ENVIRONMENT!

Risk of harm to the environment due to the incorrect handling of hazardous materials and substances.

Filters and cleaning materials that have been contaminated with bacterial, toxic or radioactive particles are considered hazardous waste and have to be disposed of by an authorised business in compliance with local regulations.

Disposing of filter elements with household waste is allowed in the following cases:

- For unused filter elements
- For filter elements that have been exposed only to atmospheric outdoor air

Ordering replacement filters

To ensure permanent protection from particulate matter and other pollutants we recommend using only original TROX filters.

Original TROX filters carry a sticker on the frame with both the use before date and information on how to order replacements.



To avoid downtime of the ventilation and air conditioning system, we recommend you to always have the required filters in stock.

To order filters go to: www.troxtechnik.com

Cleaning the filter casing

Personnel:

- Properly trained person

Protective equipment:

- Light respiratory protection

It is usually not possible to regularly clean and disinfect the ductwork between the second filter stage and the filter casing, and neither is it required for hygienic reasons. As a prerequisite, however, you have to keep the ducts clean during installation.

It is then sufficient to clean and disinfect (wipe) the filter casing and the diffuser face; this has to be done for the first time just before the ventilation and air conditioning system is switched on for the first time.

The casing may be cleaned with a damp cloth. Sticky dirt or contamination may be removed with a commercial, non-aggressive cleaning agent. Cleaning agents that contain chlorine must not be used.

Once you have completed cleaning, disinfect the filter casing and any connecting rooms.