



Circular silencer

CK

TROX GmbH

Heinrich-Trox-Platz
47504 Neukirchen-Vluyn
Germany
+49 (0) 2845 202-0
+49 (0) 2845 202-265
E-mail: trox@trox.de
www.troxtechnik.com

Product overview



Fig. 1: Schematic illustration, CK

- 1 Sound attenuator casing
- 2 Spigot
- 3 Lip seal
- 4 Splitter

Important notes

Safety

Correct use

Circular silencers are used to reduce noise in the circular ducts of ventilation and air conditioning systems within closed rooms.

For the reduction of air-regenerated noise of air terminal units and mechanical self-powered controllers, etc.

Do not use circular silencers in extract air systems in commercial kitchens unless the extract air has been cleaned as much as possible with high-efficiency aerosol separators; see VDI 2052.



Use in potentially explosive atmospheres (ATEX)

Circular silencers do not fall under the scope in accordance with Chapter 1, Article 1, Point 1a, 1b and 1c of EU Directive 2014/34/EU. The circular silencers must be used in areas with a potentially explosive atmosphere, zones 1, 2 and zones 21, 22 (outside), in accordance with Guideline 1999/92/EC.

Please note:

- Max. operating temperature 194 °F
- Max. airflow velocity 3937 fpm
- When using lip seals for tube attachment, a grounding cable must be provided for the sound attenuator/tube.
- Earth circular silencers!
- Clean sound attenuators regularly to prevent accumulated dust!
- Clean circular silencers in such a way that no electrostatic charge builds up!

Manufacturer's statement ⇒
www.troxtechnik.com.

Incorrect use



WARNING!

Danger of injury or risk of damage to property due to incorrect use

Incorrect use of the circular silencer can lead to dangerous situations.

Never use the circular silencer:

- outdoors without sufficient protection against the effects of weather
- in rooms and systems with aggressive or contaminated air (to be assessed on a case to case basis)
- in process air systems

Modifying the unit or using replacement parts that have not been approved by TROX is not permitted.

Staff

Qualification

The work described in this manual has to be carried out by individuals with the qualification, training, knowledge and experience described below:

Specialized personnel

Specialised personnel are personnel, who due to their specialized training, skills, and experience, as well as knowledge of the applicable standards and regulations, are capable of executing the tasks assigned to them, and of recognizing possible hazards and avoiding them on their own.

Personal protective equipment

Personal protective equipment is equipment that protects the user against health or safety risks at work.

Personal protective equipment must be worn for various types of work; the protective equipment required is listed in this manual together with the description of each type of work.

Description of personal protective equipment

Industrial safety helmet



Industrial safety helmets protect the head from falling objects, suspended loads, and the effects of striking the head against stationary objects.

Protective gloves



Protective gloves protect hands from friction, abrasions, punctures, deep cuts, and direct contact with hot surfaces.

Safety shoes



Safety shoes protect the feet against crushing, falling parts, and from slipping on slippery ground.

Repair and replacement parts

Only qualified personnel must repair the products, and they have to use genuine replacement parts.

Transport, storage and packaging

Delivery check

Check delivered items immediately after arrival for transport damage and completeness. In case of any damage or an incomplete shipment, contact the shipping company and your supplier immediately.

Transport on site

Please note:

- Be careful when unloading or moving the product, and pay attention to the symbols and information on the packaging.
- If possible, take the product in its transport packaging up to the installation location.
- Use only lifting and transport gear designed for the required load.
- Always secure the load against tipping and falling.
- Do not move bulky items just by yourself. Get help to prevent injuries and damage.

Storage

Please note:

- Store the product only in its original packaging
- Protect the product from the effects of weather
- Protect the product from humidity, dust and contamination
- Storage temperature: -22 °F to 194 °F.
- Relative humidity: 80 % max., no condensation

Packaging

Properly dispose of packaging material.

Installation

General installation information

Personnel:

- Specialized personnel

Protective equipment:

- Protective gloves
- Industrial safety helmet
- Safety shoes



CAUTION!

Danger of injury from sharp edges, sharp corners and thin sheet metal parts!

Sharp edges, sharp corners and thin sheet metal parts may cause cuts or grazes.

- Be careful when carrying out any work.
- Wear protective gloves, safety shoes and a hard hat.

Please note:

- Horizontal or vertical installation orientation.
- Duct connection on both sides.
- Installation in ducts outside closed rooms requires sufficient protection against the effects of weather.
- Length (L) refers to the airflow direction.
- Installation material is not part of the supply package unless stated otherwise.
- Airflow direction freely selectable.
- Torsion-free installation.

Installation information for circular silencer

General information

- When designing and constructing ventilation and air conditioning systems, take into account the requirements of VDI6022, in particular:
 - Hygienic, clean installation of all components and their air distribution surfaces
 - Inspection and cleaning options by planning inspection/cleaning openings in the ducting system
 - Avoidance of leaks
- Affix the circular silencer proficiently and only to load-bearing components.
- Load suspension systems only with the weight of the circular silencer. Adjacent components and connecting ducts must be supported separately.
- Only use approved and sufficiently dimensioned suspensions for fixing. Secure screw connections against self-loosening, e.g., by locking them. Fixing material is not included in the supply package.
- Use only the shortest possible self-tapping screws in the vicinity of the spigot for fixing

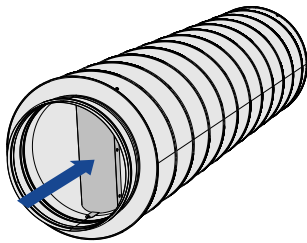

Fig. 2: Position-independent assembly

- Vertical or horizontal
- Airflow direction freely selectable

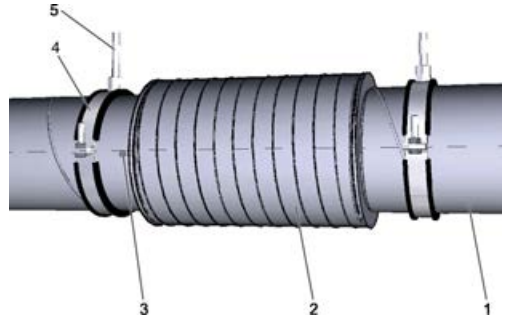

Fig. 3: Installation example for circular silencer

- 1 Duct
- 2 Circular silencer
- 3 Drilling screw for affixing to the ducting
- 4 Clamp
- 5 Suspension, e.g., with threaded rod

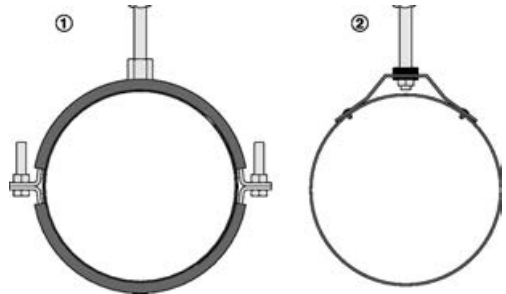

Fig. 4: Examples of fixings for rounded units

- 1 Fixing to pipe clamps
- 2 Fixing to suspension element

- When installing the circular silencer, choose a load-bearing structure that will support the entire weight of the circular silencer construction.
- The weight of the circular silencer must not be supported by the spigots or flanges alone.
- Tension-free assembly
- Structure-borne sound transmission must be avoided by taking suitable measures.
- Installation in ducts outside closed rooms requires sufficient protection against the effects of weather
- Take standard DIN EN 12236 into consideration (suspensions and supports for air ducts)

Connection in series

When connecting CK type circular silencers in series, make sure that splitters of the same thickness are arranged one behind the other in the pipe and aligned in position.

Flange constructions

Flange constructions are designed according to DIN EN 12220. Connection dimensions of the flanges can be found in the standard.

Assembly to control components

Circular silencers with splitters can be used for the reduction of air-regenerated noise of air terminal units and mechanical self-powered controllers. We recommend assembly after a settling distance of 2.5 x nominal size behind the control component.

Circular ducting – metal

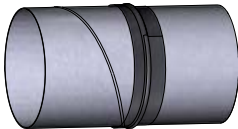

Spigot without lip seal

- Plug-in mounting on ducting in accordance with EN 1506 or EN 13180.
- Fixing and sealing with ventilation strip, e.g., KLP180.
When using heat-shrinkable tape near the spigot, watch out for plastic parts of other components and heat carefully.

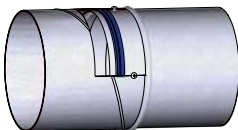

Spigot with optional lip seal

- Plug-in mounting on ducting in accordance with EN 1506 or EN 13180.
- Connect the spigot with the ducting, e.g., using drilling screws.
- No further sealing required.

Connecting the duct

When connecting the ducting, the customer must ensure that the connection points are installed as air-tight as possible in order to avoid negative influences from leakages such as air volume deviations, power consumption, etc. Unless otherwise stated, the connecting material is not included in the supply package.

Before connecting the ducting:

- Check the inside of the unit for damage and loose parts.
- Remove any contamination from the ducting.

Leakage classes

In order to be able to achieve the required tightness of the duct system, it is necessary that suitable sound attenuators and duct components have been selected. In addition, the following should be observed:

- Proper and expert assembly
- Provide seals
- Establish the cable fastening (suspension/support)

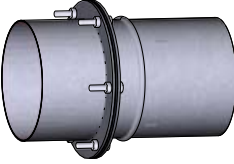
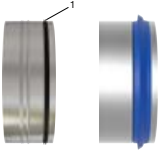
	<p>Spigot with steel flanges (galvanised steel)</p> <ul style="list-style-type: none"> ■ Matching flanges available as accessories ■ Seal and screw connection M8 (to be provided by others) ■ Dimensions and number of holes in accordance with EN 12220. ■ Position the ducting exactly. Do not pull the distances together via the flange connection.
	<p>Retrofitting of lip seals</p> <ul style="list-style-type: none"> ■ Double lip seal: Fit the short lip (1) on the connection side ■ Fit the ring seal as shown; avoid excessive stretching. ■ Check for proper seating in the groove ■ Apply talcum around the ring seal

Technical data

General data

Item	Value
Nominal sizes	10" - 39"
Operating pressure	Minimum -3 in WC 8 in WC max.
Airflow velocity	≤ 3937 fpm
Air temperature	-22 °F to 194 °F
Relative humidity	≤ 80%, no condensation
Casing leakage according to EN 15727	Class D (up to and including nominal size 16) Class C (from nominal size 18)
* No corrosion resistance according to ISO 12944-2 has been specified for circular silencers.	

Item	Value
Materials of circular silencer*	<ul style="list-style-type: none"> ■ Galvanised steel (1.0917) ■ Stainless steel V2A (1.4301) ■ Stainless steel V4A (1.4571)
* No corrosion resistance according to ISO 12944-2 has been specified for circular silencers.	

Dimensions and weights CK

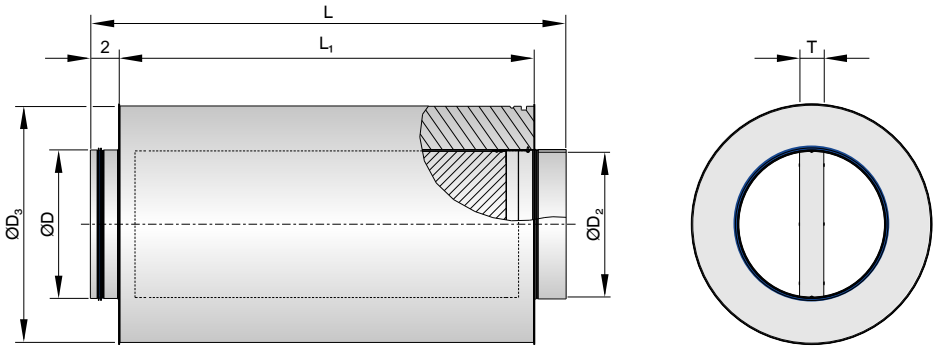

Dimensions

Nominal size	ØD	CK050		CK100	
		ØD2	ØD3	ØD2	ØD3
		[in]			
10	10	10	14	10	18
12	12	12	16	12	20
16	16	16	20	16	24
18	18			18	25
20	20			20	28
22	22			22	32
25	25			25	32
28	28			28	36
31	31			31	40
35	35			35	44
39	39			39	50

No entry required: Spigot with groove to EN1506/ØD
 D2 Spigot with lip seal on both ends according to EN 1506/ØD
 AS Spigot with lip seal - ØD and socket-type spigot on one end - ØD2
 ØD3 outer diameter

Lengths

Nominal length	L	L1
	[in]	
20	20	15
39	39	35
59	59	54

CK-0, weights without splitter (spiral duct casing)

Nominal size	CK050			CK100		
	20	39	59	20	39	59
	m [lbs]					
10	13	24	33	20	33	46
12	18	31	44	22	37	53
16	22	37	55	31	55	79
18				33	57	82
20				40	68	97
22				44	77	110
25				46	82	115
28				57	104	150
31				66	117	170
35				77	139	201
39				84	152	223

CK-A2, Weights without splitter (casing for pipe with plain tails)

Nominal size	CK050			CK100		
	20	39	59	20	39	59
	m [lbs]					
10	15	26	37	20	33	49
12	18	31	46	22	40	55
16	22	37	57	29	51	71
18				31	53	73
20				35	62	88
22				40	71	99
25				44	75	104
28				51	84	119
31				57	97	137
35				66	117	165
39				75	130	185

CK-...x20, splitter weights

LN 20	T					
Nominal size	2	4	6	8	10	12
	m [lbs]					
10	2	4				
12	2	4				
16		4	7			
18		4	7			

LN 20	T					
Nominal size	2	4	6	8	10	12
	m [lbs]					
20			7	9		
22			7	9		
25				11	13	
28				11	13	
31					15	18
35					18	20
39						22

CK-...x39, splitter weights

LN 39	T					
Nominal size	2	4	6	8	10	12
	m [lbs]					
10	4	7				
12	4	7				
16		9	11			
18		9	11			
20			11	15		
22			13	15		
25				18	22	
28				20	22	
31					24	29
35					26	33
39						35

CK-...x59, splitter weights

LN 59	T					
Nominal size	2	4	6	8	10	12
	m [lbs]					
10	7	9				
12	7	9				
16		11	15			
18		11	15			
20			18	22		
22			18	22		
25				24	31	
28				26	33	
31					35	42

LN 59	T					
Nominal size	2	4	6	8	10	12
	m [lbs]					
35					40	46
39						49

Commissioning

Commissioning and operation

Personnel:

- Specialized personnel
 - ▶ Before you start commissioning:
 - Check proper installation of the circular silencers.
 - Ensure that all sound attenuators are clean and free from residues and foreign matter.

Commissioning



Code of good practice for commissioning

Commissioning is governed by the standard "DIN EN 12599 Testing and measuring procedures for the transfer of installed ventilation and air conditioning systems", and, if applicable, contractually agreed services between HVAC contractors, system owners and installation engineers. The standard describes the essential commissioning steps of the completeness check, function check, function measurement as well as report generation and handover.

Operation

Once commissioning has been completed, the circular silencer will operate in a self-powered manner and require no intervention from the system owner.

Depending on the area of application of the circular silencer, test specifications and intervals may have to be observed.

Maintenance

System owner's responsibility



WARNING!

Only authorised specialist personnel are allowed to perform the described maintenance measures.

The system owner is responsible for maintenance. The system owner is responsible for creating a maintenance plan, for defining the maintenance goals, and for the functional reliability of the equipment.

The legal regulations must be observed during maintenance, e.g. the system owner is responsible for hygienic operation in accordance with VDI 6022.

Maintenance

The circular silencers are low-maintenance in terms of wear, but they must be included in the regular cleaning of the ventilation system. Regular care and maintenance ensure long service life of the circular silencer.

Inspection measures

1. ▶ Remove contamination that affects the function of the circular silencer.
2. ▶ Check all screws for firm seating and retighten them, if necessary.
3. ▶ Document the maintenance work.

Repair

Repair work is only allowed to be carried out by specialist personnel or by the manufacturer. Only genuine replacement parts must be used.

Disposal

 ENVIRONMENT!

Risk of harm to the environment due to incorrect disposal of goods and packaging!

Incorrect disposal can harm the environment.

- Be sure to comply with the relevant national guidelines and regulations.
- If you are not sure how to dispose of anything in an environmentally friendly manner, contact your local authorities or a specialist disposal company.

Note: The sound attenuator has to be disassembled for disposal.
 If no take back (disposal) agreement with TROX GmbH is in place, we recommend disposing of the various materials as described below:

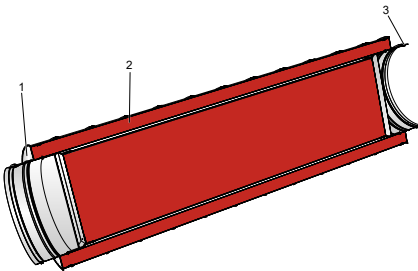

Fig. 5: Schematic illustration of the circular silencer

No.	Part	Material/ waste disposal code	Disposal
1	Casing, inner duct, spigot and splitter frame	Galvanised sheet steel, stainless steel EAK 170405	Scrap and metal recycling
2	Absorption material	Mineral wool EAK 170604	According to EAK
3	Lip seal, cover fleece	Plastic EAK 170203	According to EAK

EWC European Waste Catalogue